

18

Unified design of linear transceivers for MIMO channels

Daniel Pérez Palomar

MIMO communication systems with CSI at both sides of the link can adapt to each channel realization to optimize the spectral efficiency and/or the reliability of the communication. A low-complexity approach with high potential is the use of linear MIMO transceivers (composed of a linear precoder at the transmitter and a linear equalizer at the receiver). The design of linear transceivers has been studied for many years (the first papers dating back to the 1970s) based on very simple cost functions as a measure of the system quality such as the trace of the MSE matrix. If more reasonable measures of quality are considered, the problem becomes much more complicated due to its nonconvexity and to the matrix-valued variables. Recent results showed how to solve the problem in an optimal way for the family of Schur-concave and Schur-convex cost functions. Although this is a quite general result, there are some interesting functions that fall outside of this category such as the minimization of the average BER when different constellations are used. In this chapter, these results are further generalized to include any cost function as a measure of the quality of the system. When the function is convex, the original complicated nonconvex problem with matrix-valued variables can always be reformulated a simple convex problem with scalar-valued variables. The simplified problem can then be addressed under the powerful framework of convex optimization theory, in which a great number of interesting design criteria can be easily accommodated and efficiently solved even though closed-form expressions may not exist.

18.1. Introduction

Multiple-input multiple-output (MIMO) channels are an abstract and general way to model many different communication systems of diverse physical nature; ranging from wireless multiantenna channels [1, 2, 3, 4] (see Figure 18.1) to wireline digital subscriber line (DSL) systems [5], and to single-antenna frequency-selective channels [6]. In particular, wireless multiantenna MIMO channels have been recently attracting a significant interest because they provide an important increase of spectral efficiency with respect to single-input single-output (SISO)

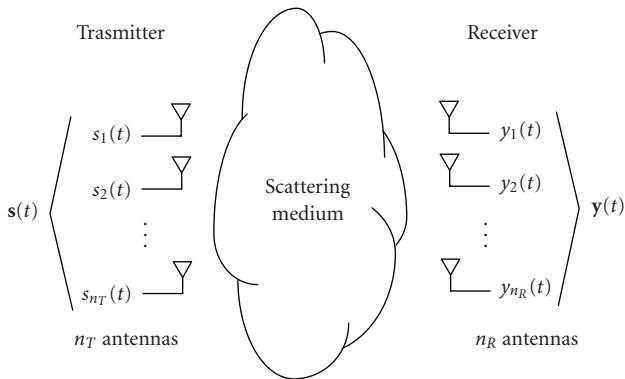

FIGURE 18.1. Example of a MIMO channel arising in wireless communications with multiple antennas at both the transmitter and the receiver.

channels [3, 4]. This abstract MIMO modeling allows for a unified treatment using a very elegant and convenient vector-matrix notation.

This chapter considers point-to-point MIMO communication systems with channel state information (CSI) at both sides of the link (cf. Section 18.2). For the case of no CSI at the transmitter, a great number of techniques have also been proposed in the literature which can globally referred to as *space-time coding* [1, 7, 8].

MIMO systems are not just mathematically more involved than SISO systems but also conceptually different and more complicated. Several substreams are typically established in MIMO channels (so-called multiplexing property [9]), whereas SISO channels can only support a single substream of information. It is this increase of dimensionality that makes the mathematical notation more involved, in the sense that the manipulation of scalar quantities becomes a vector-matrix manipulation. In addition, the existence of several substreams, each with its own quality, makes the definition of a global measure of the system quality very difficult; as a consequence, different design criteria have been pursued in the literature (cf. Section 18.2). In fact, such a problem is a multiobjective optimization problem characterized by not having just optimal solutions (as happens in single-objective optimization problems) but a set of Pareto-optimal solutions¹ [10]. Although to fully characterize such a problem, the Pareto-optimal set should be obtained, it is generally more convenient to use a single measure of the system quality to simplify the characterization.

Theoretically, the design of MIMO systems with CSI at both sides of the link has been known since 1948, when Shannon, in his ground-breaking paper [11], defined the concept of channel capacity—the maximum reliably achievable rate—and obtained the capacity-achieving signaling strategy. In particular, for a given realization of a MIMO channel, the optimal transmission is given by a Gaussian

¹A Pareto-optimal solution is defined as any solution that cannot be improved with respect to any component without worsening the others [10].

signaling with a water-filling power profile over the channel eigenmodes [2, 3, 12]. From a more practical standpoint, however, the ideal Gaussian codes are substituted with practical constellations (such as QAM constellations) and coding schemes. To simplify the study of such a system, it is customary to divide it into an uncoded part, which transmits symbols drawn from some constellations, and a coded part that builds upon the uncoded system. Although the ultimate system performance depends on the combination of both parts (in fact, for some systems, such a division does not apply), it is convenient to consider the uncoded and coded parts independently to simplify the analysis and design. The focus of this chapter is on the uncoded part of the system and, specifically, on the employment of linear transceivers (composed of a linear precoder at the transmitter and a linear equalizer at the receiver) for complexity reasons.²

Hence, the problem faced when designing a MIMO system not only lies on the design itself but also on the choice of the appropriate measure of the system quality (which may depend on the application at hand and/or on the type of coding used on top of the uncoded system). The traditional results existing in the literature have dealt with the problem from a narrow perspective (due to the complexity of the problem); the basic approach has been to choose a measure of quality of the system sufficiently simple such that the problem can be analytically solved. Recent results have considered more elaborated and meaningful measures of quality. In the sequel, a unified framework for the systematic design of linear MIMO transceivers is developed.

This chapter is structured as follows. Section 18.2 gives an overview of the classical and recent results existing in the literature. After describing the signal model in Section 18.3, the general problem to be addressed is formulated in Section 18.4. Then, Section 18.5 gives the optimal receiver and Section 18.6 obtains the main result of this chapter: the unified framework for the optimization of the transmitter under different criteria. Section 18.7 addresses the issue of the diagonal/nondiagonal structure of the optimal transmission. Several illustrative examples are considered in detail in Section 18.8. The extension of the results to multiple MIMO channels is described in Section 18.9. Some numerical results are given in Section 18.10 to exemplify the application of the developed framework. Finally, Section 18.11 summarizes the main results of the chapter.

The following notation is used. Boldface uppercase letters denote matrices, boldface lowercase letters denote column vectors, and italics denote scalars. $\mathbb{R}^{m \times n}$ and $\mathbb{C}^{m \times n}$ represent the set of $m \times n$ matrices with real- and complex-valued entries, respectively. The superscripts $(\cdot)^T$, $(\cdot)^*$, and $(\cdot)^H$ denote transpose, complex conjugate, and Hermitian operations, respectively. $[\mathbf{X}]_{i,j}$ (also $[\mathbf{X}]_{ij}$) denotes the (i th, j th) element of matrix \mathbf{X} . $\text{Tr}(\cdot)$ and $\det(\cdot)$ denote the trace and determinant of a matrix, respectively. A block-diagonal matrix with diagonal blocks given by the set $\{\mathbf{X}_k\}$ is denoted by $\text{diag}\{\{\mathbf{X}_k\}\}$. The operator $(x)^+ \triangleq \max(0, x)$ is the projection onto the nonnegative orthant.

²The choice of linear transceivers is also supported by their optimality from an information-theoretic viewpoint.

18.2. Historical overview of MIMO transceivers

The design of linear MIMO transceivers has been studied since the 1970s where cable systems were the main application [13, 14]. Initially, since the problem is very complicated, it was tackled by optimizing easily tractable cost function as a measure of the system quality such as the sum of the mean square error (MSE) of all channel substreams or, equivalently, the trace of the MSE matrix [6, 13, 14, 15]. Others examples include the minimization of the weighted trace of the MSE matrix [16], the minimization of the determinant of the MSE matrix [17], and the maximization of the signal-to-interference-plus-noise ratio (SINR) criterion with a zero-forcing (ZF) constraint [6]. Some criteria were considered under a peak power constraint in [18].

For these criteria, the original complicated design problem is greatly simplified because the channel turns out to be diagonalized by the optimal transmit-receive processing and the transmission is effectively performed on a diagonal or parallel fashion. The diagonal transmission allows a *scalarization* of the problem (meaning that all matrix equations are substituted with scalar ones) with the consequent simplification. In light of the optimality of the diagonal structure for transmission in all the aforementioned examples (including the capacity-achieving solution [3, 12, 19]), one may expect that the same holds for other criteria as well.

In [20], a general unifying framework was developed that embraces a wide range of different design criteria; in particular, the optimal design was obtained for the family of Schur-concave and Schur-convex cost functions which arise in majorization theory [21]. Interestingly, this framework gives a clear answer to the question of when the diagonal transmission is optimal.

However, rather than the MSE or the SINR, the ultimate performance of a system is given by the bit error rate (BER), which is more difficult to handle. In [22], the minimization of the BER (and also of the Chernoff upper bound) averaged over the channel substreams was treated in detail when a diagonal structure is imposed. Recently, the minimum BER design without the diagonal structure constraint has been independently obtained in [20, 23], resulting in an optimal nondiagonal structure. This result, however, only applies when the constellations used in all channel substreams are equal (in which case the cost function happens to be Schur-convex [20]). The general case of different constellations is much more involved (in such a case, the cost function is neither Schur-convex nor Schur-concave) and was solved in [24] via a primal decomposition approach.

There are two natural extensions of the existing results on point-to-point MIMO transceivers: to the case of imperfect CSI and to the multiuser scenario. With imperfect CSI (due, e.g., to estimation errors), robust transceivers are necessary to cope with the uncertainty. The existing results along this line are very few and further work is still needed; some results were obtained in [25, 26] with a worst-case robust approach and in [27, 28] with a stochastic robust approach (see also [29] for a combination of space-time coding with linear precoding). Regarding the extension to the multiuser scenario, the existing results are very scarce: in

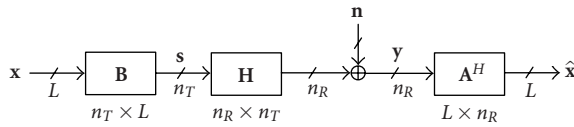

FIGURE 18.2. Scheme of a general MIMO communication system with a linear transceiver.

[30], a suboptimal joint design of the transmit-receive beamforming and power allocation in a wireless network was proposed; and, in [31], the optimal MIMO transceiver design in a multiple-access channel was obtained in terms of minimizing the sum of the MSEs of all the substreams and of all users (a similar approach was employed in [32] for a broadcast channel). Iterative single-user methods have also been applied to the multiuser case with excellent performance [33, 34].

In the sequel, the problem of linear MIMO transceiver design is formulated and solved in a very general way for an arbitrary cost function as a measure of the system quality. The design can then be approached from a unified perspective that provides great insight into the problem and simplifies it. The key step is in reformulating the originally nonconvex problem in convex form after some manipulations based on majorization theory [21]. The simplified problem can then be addressed under the powerful framework of convex optimization theory [35, 36], in which a great number of interesting design criteria can be easily accommodated and efficiently solved even though closed-form expressions may not exist.

18.3. System model

The signal model corresponding to a transmission through a general MIMO communication channel with n_T transmit and n_R receive dimensions is

$$\mathbf{y} = \mathbf{H}\mathbf{s} + \mathbf{n}, \quad (18.1)$$

where $\mathbf{s} \in \mathbb{C}^{n_T \times 1}$ is the transmitted vector, $\mathbf{H} \in \mathbb{C}^{n_R \times n_T}$ is the channel matrix, $\mathbf{y} \in \mathbb{C}^{n_R \times 1}$ is the received vector, and $\mathbf{n} \in \mathbb{C}^{n_R \times 1}$ is a zero-mean circularly symmetric complex Gaussian interference-plus-noise vector with arbitrary covariance matrix \mathbf{R}_n .

The transmitted vector can be written as (see Figure 18.2)

$$\mathbf{s} = \mathbf{B}\mathbf{x}, \quad (18.2)$$

where $\mathbf{B} \in \mathbb{C}^{n_T \times L}$ is the transmit matrix (precoder) and $\mathbf{x} \in \mathbb{C}^{L \times 1}$ is the data vector that contains the L symbols to be transmitted (zero mean,³ normalized and uncorrelated, that is, $\mathbb{E}[\mathbf{x}\mathbf{x}^H] = \mathbf{I}$) drawn from a set of constellations. For the sake

³If a constellation does not have zero mean, the receiver can always remove the mean and then proceed as if the mean was zero, resulting in a loss of transmitted power. Indeed, the mean of the signal does not carry any information and can always be set to zero saving power at the transmitter.

of notation, it is assumed that $L \leq \min(n_R, n_T)$. The total average transmitted power (in units of energy per transmission) is

$$P_T = \mathbb{E}[\|\mathbf{s}\|^2] = \text{Tr}(\mathbf{B}\mathbf{B}^H). \quad (18.3)$$

Similarly, the estimated data vector at the receiver is (see Figure 18.2)

$$\hat{\mathbf{x}} = \mathbf{A}^H \mathbf{y}, \quad (18.4)$$

where $\mathbf{A}^H \in \mathbb{C}^{L \times n_R}$ is the receive matrix (equalizer).

It is interesting to observe that the i th column of \mathbf{B} and \mathbf{A} , \mathbf{b}_i and \mathbf{a}_i , respectively, can be interpreted as the transmit and receive beam vectors, respectively, associated to the i th transmitted symbol x_i :

$$\hat{x}_i = \mathbf{a}_i^H (\mathbf{H}\mathbf{b}_i x_i + \mathbf{n}_i), \quad (18.5)$$

where $\mathbf{n}_i = \sum_{j \neq i} \mathbf{H}\mathbf{b}_j x_j + \mathbf{n}$ is the equivalent noise seen by the i th substream, with covariance matrix $\mathbf{R}_{n_i} = \sum_{j \neq i} \mathbf{H}\mathbf{b}_j \mathbf{b}_j^H \mathbf{H}^H + \mathbf{R}_n$.

It is worth noting that in some particular scenarios such as in multicarrier systems, although the previous signal model can be directly applied by properly defining the channel matrix \mathbf{H} as a block-diagonal matrix containing the channel at each carrier, it may also be useful to model the system as a set of parallel and noninterfering MIMO channels (cf. Section 18.9).

18.3.1. Measures of quality

The quality of the i th established substream or link in (18.5) can be conveniently measured, among others, in terms of MSE, SINR, or BER, defined, respectively, as

$$\text{MSE}_i \triangleq \mathbb{E}[|\hat{x}_i - x_i|^2] = |\mathbf{a}_i^H \mathbf{H}\mathbf{b}_i - 1|^2 + \mathbf{a}_i^H \mathbf{R}_{n_i} \mathbf{a}_i, \quad (18.6)$$

$$\text{SINR}_i \triangleq \frac{\text{desired component}}{\text{undesired component}} = \frac{|\mathbf{a}_i^H \mathbf{H}\mathbf{b}_i|^2}{\mathbf{a}_i^H \mathbf{R}_{n_i} \mathbf{a}_i}, \quad (18.7)$$

$$\text{BER}_i \triangleq \frac{\# \text{ bits in error}}{\# \text{ transmitted bits}} \approx \tilde{g}_i(\text{SINR}_i), \quad (18.8)$$

where \tilde{g}_i is a function that relates the BER to the SINR at the i th substream. For most types of modulations, the BER can indeed be analytically expressed as a function of the SINR when the interference-plus-noise term follows a Gaussian distribution [37, 38, 39]; otherwise, it is an approximation (see [24] for a more detailed discussion). For example, for square M -ary QAM constellations, the BER is [37, 39]

$$\text{BER}(\text{SINR}) \approx \frac{4}{\log_2 M} \left(1 - \frac{1}{\sqrt{M}}\right) \mathcal{Q}\left(\sqrt{\frac{3}{M-1}} \text{SINR}\right), \quad (18.9)$$

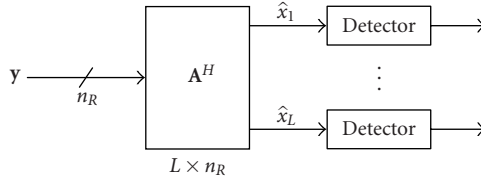

FIGURE 18.3. Independent detection of the substreams after the joint linear processing with matrix \mathbf{A} .

where \mathcal{Q} is the \mathcal{Q} -function defined as $\mathcal{Q}(x) \triangleq (1/\sqrt{2\pi}) \int_x^\infty e^{-\lambda^2/2} d\lambda$ [38].⁴ It is sometimes convenient to use the Chernoff upper bound of the tail of the Gaussian distribution function $\mathcal{Q}(x) \leq (1/2)e^{-x^2/2}$ [38] to approximate the symbol error probability (which becomes a reasonable approximation for high values of the SINR).

It is worth pointing out that expressing the BER as in (18.8) implicitly assumes that the different links are independently detected after the joint linear processing with the receive matrix \mathbf{A} (see Figure 18.3). This reduces the complexity drastically compared to a joint maximum-likelihood (ML) detection and is indeed the main advantage of using the receive matrix \mathbf{A} .

Any properly designed system should attempt to somehow minimize the MSEs, maximize the SINRs, or minimize the BERs, as is mathematically formulated in the next section.

18.4. General problem formulation

The problem addressed in this chapter is the optimal design of a linear MIMO transceiver (matrices \mathbf{A} and \mathbf{B}) as a tradeoff between the power transmitted and the quality achieved. To be more specific, the problem can be formulated as the minimization of some cost function f_0 of the MSEs in (18.6), which measures the system quality (a smaller value of f_0 means a better quality), subject to a transmit power constraint [20, 40]:

$$\begin{aligned} \min_{\mathbf{A}, \mathbf{B}} f_0(\{ \text{MSE}_i \}) \\ \text{s.t. } \text{Tr}(\mathbf{B}\mathbf{B}^H) \leq P_0 \end{aligned} \tag{18.10}$$

or, conversely, as the minimization of the transmit power subject to a constraint on the quality of the system:

$$\begin{aligned} \min_{\mathbf{A}, \mathbf{B}} \text{Tr}(\mathbf{B}\mathbf{B}^H) \\ \text{s.t. } f_0(\{ \text{MSE}_i \}) \leq \alpha_0, \end{aligned} \tag{18.11}$$

where P_0 and α_0 denote the maximum values for the power and for the cost function, respectively.

⁴The complementary error function is related to the \mathcal{Q} -function as $\text{erfc}(x) = 2\mathcal{Q}(\sqrt{2}x)$ [38].

The cost function f_0 is an indicator of how well the system performs and should be properly selected for the problem at hand. In principle, any function can be used to measure the system quality as long as it is strictly increasing in each argument. Note that the increasingness of f_0 is a mild and completely reasonable assumption: if the quality of one of the substream improves while the rest remain unchanged, any reasonable function should properly reflect this difference.

The problem formulations in (18.10) and (18.11) are in terms of a cost function of the MSEs; however, similar design problems can be straightforwardly formulated with cost functions of the SINRs and of the BERs (when using cost functions of the BERs, it is implicitly assumed that the constellations have already been chosen such that (18.8) can be employed).

Alternatively, it is also possible to consider independent constraints on each of the links rather than a global measure of the quality [26, 40]:

$$\begin{aligned} \min_{\mathbf{A}, \mathbf{B}} \quad & \text{Tr}(\mathbf{B}\mathbf{B}^H) \\ \text{s.t.} \quad & \text{MSE}_i \leq \rho_i \quad 1 \leq i \leq L, \end{aligned} \quad (18.12)$$

where ρ_i denotes the maximum MSE value for the i th substream. Constraints in terms of SINR and BER can be similarly considered. Note that the solution to problem (18.12) allows a more detailed characterization of the fundamental multiobjective nature of the problem [10]; it allows, for example, to compute the exact region of achievable MSEs for a given power budget.

For the sake of space, this chapter focuses on the power-constrained problem in (18.10). The quality-constrained problem in (18.11), however, is so closely related that the results obtained also hold for this problem (in particular, Theorem 18.1 holds for problem (18.11)). Problem (18.12) is mathematically more involved and the interested reader is referred to [24, 26, 40].

If fact, since problems (18.10) and (18.11) characterize the same strictly monotonic tradeoff curve of power versus quality, each of them can be easily solved by iteratively solving the other one using, for example, the bisection method [35, Algorithm 4.1].

18.5. Receiver design

The receive matrix \mathbf{A} can be easily optimized for a given fixed transmit matrix \mathbf{B} . In principle, the optimal receive matrix may depend on the specific choice of the cost function f_0 . However, it turns out that the optimal solution is independent of f_0 as is now briefly described (for more details, the reader is referred to [20, 40]).

It will be notationally convenient to define the MSE matrix as

$$\mathbf{E} \triangleq \mathbb{E}[(\hat{\mathbf{x}} - \mathbf{x})(\hat{\mathbf{x}} - \mathbf{x})^H] = (\mathbf{A}^H \mathbf{H} \mathbf{B} - \mathbf{I})(\mathbf{B}^H \mathbf{H}^H \mathbf{A} - \mathbf{I}) + \mathbf{A}^H \mathbf{R}_n \mathbf{A} \quad (18.13)$$

from which the MSE of the i th link is obtained as the i th diagonal element of \mathbf{E} , that is, $\text{MSE}_i = [\mathbf{E}]_{ii}$.

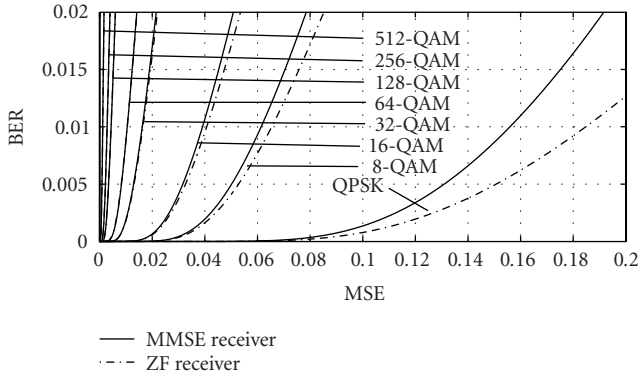

FIGURE 18.4. BER as a function of the MSE for different QAM constellations.

The minimization of the MSE of a substream with respect to the receive matrix \mathbf{A} (for a fixed transmit matrix \mathbf{B}) does not incur any penalty on the other substreams (see, e.g., (18.5) where \mathbf{a}_i only affects \hat{x}_i); in other words, there is no tradeoff among the MSEs and the problem decouples. Therefore, it is possible to minimize simultaneously all MSEs and this is precisely how the well-known linear minimum MSE (MMSE) receiver, also termed Wiener filter, is obtained [41] (see also [20, 26]). If the additional ZF constraint $\mathbf{A}^H \mathbf{H} \mathbf{B} = \mathbf{I}$ is imposed to avoid crosstalk among the substreams (which may happen with the MMSE receiver), then the well-known ZF receiver is obtained [40]. Interestingly, the MMSE and ZF receivers are also optimum in the sense that they maximize simultaneously all SINRs and, consequently, minimize simultaneously all BERs (cf. [20, 40]).

The MMSE and ZF receivers can be compactly written as

$$\mathbf{A} = \mathbf{R}_n^{-1} \mathbf{H} \mathbf{B} (\nu \mathbf{I} + \mathbf{B}^H \mathbf{H}^H \mathbf{R}_n^{-1} \mathbf{H} \mathbf{B})^{-1}, \tag{18.14}$$

where ν is a parameter defined as

$$\nu \triangleq \begin{cases} 1 & \text{for the MMSE receiver,} \\ 0 & \text{for the ZF receiver.} \end{cases} \tag{18.15}$$

The MSE matrix reduces then to the following concentrated MSE matrix:

$$\mathbf{E} = (\nu \mathbf{I} + \mathbf{B}^H \mathbf{R}_H \mathbf{B})^{-1}, \tag{18.16}$$

where $\mathbf{R}_H \triangleq \mathbf{H}^H \mathbf{R}_n^{-1} \mathbf{H}$ is the squared whitened channel matrix.

18.5.1. Relation among different measures of quality

It is convenient now to relate the different measures of quality, namely, MSE, SINR, and BER, to the concentrated MSE matrix in (18.16).

From the definition of MSE matrix, the individual MSEs are given by the diagonal elements:

$$\text{MSE}_i = [(\nu \mathbf{I} + \mathbf{B}^H \mathbf{R}_H \mathbf{B})^{-1}]_{ii}. \quad (18.17)$$

It turns out that the SINRs and the MSEs are trivially related when using the MMSE or ZF receivers as [20, 26, 40]

$$\text{SINR}_i = \frac{1}{\text{MSE}_i} - \nu. \quad (18.18)$$

Finally, the BERs can also be written as a function of the MSEs:

$$\text{BER}_i = g_i(\text{MSE}_i) \triangleq \tilde{g}_i(\text{SINR}_i = \text{MSE}_i^{-1} - \nu), \quad (18.19)$$

where \tilde{g}_i was defined in (18.8).

It is important to remark that the BER functions \tilde{g}_i are convex decreasing in the SINR and the BER functions g_i are convex increasing in the MSE for sufficiently small values of the argument (see Figure 18.4) [20, 40] (this last property will be key when proving later in Section 18.8.2 that the average BER function is Schur-convex). As a rule of thumb, the BER as a function of the MSE is convex for a BER less than 2×10^{-2} (this is a mild assumption, since practical systems have in general a smaller uncoded BER⁵); interestingly, for BPSK and QPSK constellations, the BER function is always convex [20, 40].

Summarizing, the MMSE and ZF receivers have been obtained as the optimum solution in the sense of minimizing the MSEs, maximizing the SINRs, and minimizing the BERs. In addition, since the SINR and the BER can be expressed as a function of the MSE, (18.18) and (18.19), it suffices to focus on cost functions of the MSEs without loss of generality.

18.6. Transmitter design

Now that the MMSE and ZF receivers have been obtained as optimal solutions, the main problem addressed in this chapter can be finally formulated: the optimization of the transmit matrix \mathbf{B} for an arbitrary cost function of the MSEs (recall that cost functions of the SINRs and BERs can always be reformulated as functions of the MSEs).

Theorem 18.1. The following complicated nonconvex constrained optimization problem:

$$\begin{aligned} \min_{\mathbf{B}} f_0 \left(\left\{ [(\nu \mathbf{I} + \mathbf{B}^H \mathbf{R}_H \mathbf{B})^{-1}]_{ii} \right\} \right) \\ \text{s.t.} \quad \text{Tr}(\mathbf{B} \mathbf{B}^H) \leq P_0, \end{aligned} \quad (18.20)$$

⁵Given an uncoded bit error probability of at most 10^{-2} and using a proper coding scheme, coded bit error probabilities with acceptable low values such as 10^{-6} can be obtained.

where $f_0 : \mathbb{R}^L \rightarrow \mathbb{R}$ is an arbitrary cost function (increasing in each argument and minimized when the arguments are sorted in decreasing order⁶), is equivalent to the simple problem

$$\begin{aligned}
 & \min_{\mathbf{p}, \rho} f_0(\rho_1, \dots, \rho_L) \\
 \text{s.t.} \quad & \sum_{j=i}^L \frac{1}{v + p_j \lambda_{H,j}} \leq \sum_{j=i}^L \rho_j, \quad 1 \leq i \leq L, \\
 & \rho_i \geq \rho_{i+1}, \\
 & \sum_{j=1}^L p_j \leq P_0, \\
 & p_i \geq 0,
 \end{aligned} \tag{18.21}$$

where the $\lambda_{H,i}$'s are L largest eigenvalues of \mathbf{R}_H sorted in increasing order $\lambda_{H,i} \leq \lambda_{H,i+1}$ and $\rho_{L+1} \triangleq 0$. Furthermore, if f_0 is a convex function, problem (18.21) is convex and the ordering constraint $\rho_i \geq \rho_{i+1}$ can be removed.

More specifically, the optimal solution to problem (18.20) is given by

$$\mathbf{B} = \mathbf{U}_{H,1} \mathbf{\Sigma}_B \mathbf{Q}, \tag{18.22}$$

where $\mathbf{U}_{H,1} \in \mathbb{C}^{n_T \times L}$ is a (semi-)unitary matrix that has as columns the eigenvectors of \mathbf{R}_H corresponding to the L largest eigenvalues in increasing order, $\mathbf{\Sigma}_B = \text{diag}(\{\sqrt{p_i}\}) \in \mathbb{R}^{L \times L}$ is a diagonal matrix with the optimal power allocation $\{p_i\}$ obtained as the solution to problem (18.21), and \mathbf{Q} is a unitary matrix such that $[(v\mathbf{I} + \mathbf{B}^H \mathbf{R}_H \mathbf{B})^{-1}]_{ii} = \rho_i$ for $1 \leq i \leq L$ (see [42, Section IV-A] for a practical algorithm to obtain \mathbf{Q}).

In addition, the optimal solution can be further characterized for two particular cases of cost functions.

(i) If f_0 is Schur-concave, then an optimal solution is

$$\mathbf{B} = \mathbf{U}_{H,1} \mathbf{\Sigma}_B. \tag{18.23}$$

(ii) If f_0 is Schur-convex, then an optimal solution is

$$\mathbf{B} = \mathbf{U}_{H,1} \mathbf{\Sigma}_B \mathbf{Q}, \tag{18.24}$$

where \mathbf{Q} is a unitary matrix such that $(\mathbf{I} + \mathbf{B}^H \mathbf{R}_H \mathbf{B})^{-1}$ has identical diagonal elements. This rotation matrix \mathbf{Q} can be computed with the algorithm in [42, Section IV-A], as well as with any unitary matrix that satisfies $|\mathbf{Q}_{ik}| = |\mathbf{Q}_{il}|$, for all i, k, l such as the unitary discrete Fourier transform (DFT) matrix or the unitary

⁶In practice, most cost functions are minimized when the arguments are in a specific ordering (if not, one can always use instead the function $\tilde{f}_0(\mathbf{x}) = \min_{\mathbf{P} \in \mathcal{P}} f_0(\mathbf{P}\mathbf{x})$, where \mathcal{P} is the set of all permutation matrices) and, hence, the decreasing ordering can be taken without loss of generality.

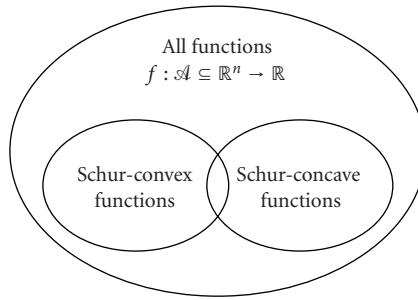

FIGURE 18.5. Illustration of the sets of Schur-convex and Schur-concave functions within the set of all functions $f : \mathcal{A} \subseteq \mathbb{R}^n \rightarrow \mathbb{R}$.

Hadamard matrix (when the dimensions are appropriate such as a power of two [38, page 66]).

Proof. The key simplification from (18.20) to (18.21) is based on an appropriate change of variable based on majorization theory [21]. A sketch of the proof is given in the appendix (see [20, 40] for details). \square

Note that Theorem 18.1 is a generalization of previous results [20, 40] which only considered Schur-concave and Schur-convex functions.

Some comments on Theorem 18.1 are in order.

(i) The main result is in the simplification of the original complicated problem (18.20) with a matrix-valued variable to the simple problem (18.21) with a set of scalar variables that represent a power allocation over the channel eigenvalues. In other words, the problem has been *scalarized* in the sense that no matrix appears.

(ii) As stated in the theorem, when f_0 is a convex function, then the simplified problem (18.21) is convex. This has tremendous consequences, since the problem can always be optimally solved using the existing tools in convex optimization theory, either in closed-form (using the Karush-Kuhn-Tucker optimality conditions) or at least numerically (using very efficient algorithms recently developed such as interior-point methods) [35, 36]. Furthermore, additional constraints on the design can be easily incorporated without affecting the solvability of the problem as long as they are convex (cf. [20, 40]).

(iii) For Schur-concave/convex cost functions, the problem (18.21) is extremely simplified (cf. Sections 18.6.1 and 18.6.2) and in most cases closed-form solutions can be obtained (see Section 18.8 for a list of Schur-concave/convex cost functions and for a detailed treatment of two interesting cases such as the minimization of the average BER and the optimization of the worst substream).

(iv) The sets of Schur-concave and Schur-convex functions do not form a partition of the set of all functions as illustrated in Figure 18.5. This means that there may be cost functions that are neither Schur-concave nor Schur-convex (cf. Section 18.8.2). On the other hand, there are cost functions that are both Schur-concave and Schur-convex, such as $\text{Tr}(\mathbf{E})$, and admit any rotation matrix \mathbf{Q} [40].

(v) Surprisingly, for Schur-convex cost functions f_0 , the optimal solution to the original problem (18.20) is independent of the specific choice of f_0 (cf. Section 18.6.2), as opposed to Schur-concave cost functions, whose solution depends on the particular choice of f_0 .

(vi) As is explained in detail in Section 18.7, for Schur-concave functions, the optimal transmission is fully diagonal, whereas for Schur-convex functions, it is not due to the additional rotation matrix \mathbf{Q} (see Figure 18.6)

(vii) For the simple case in which a single substream is established, that is, $L = 1$, the result in Theorem 18.1 simply means that the eigenmode with highest gain should be used.

18.6.1. Schur-concave cost functions

For Schur-concave cost functions, since the optimal rotation is $\mathbf{Q} = \mathbf{I}$ (from Theorem 18.1), the MSEs are given by

$$\text{MSE}_i = \frac{1}{v + p_i \lambda_{H,i}}, \quad 1 \leq i \leq L \quad (18.25)$$

and the original optimization problem (18.20) can be finally written as

$$\begin{aligned} \min_{\mathbf{p}} f_0 \left(\left\{ \frac{1}{v + p_i \lambda_{H,i}} \right\}_i \right) \\ \text{s.t.} \quad \sum_{j=1}^L p_j \leq P_0, \\ p_i \geq 0, \quad 1 \leq i \leq L. \end{aligned} \quad (18.26)$$

The solution to problem (18.26) clearly depends on the particular choice of f_0 .

18.6.2. Schur-convex cost functions

For Schur-convex cost functions, since the diagonal elements of \mathbf{E} are equal at the optimal solution (from Theorem 18.1), the MSEs are given by

$$\text{MSE}_i = \frac{1}{L} \text{Tr}(\mathbf{E}) = \frac{1}{L} \sum_{j=1}^L \frac{1}{v + p_j \lambda_{H,j}}, \quad 1 \leq i \leq L \quad (18.27)$$

and the original optimization problem (18.20) can be finally written as

$$\begin{aligned} \min_{\mathbf{p}} \frac{1}{L} \sum_{j=1}^L \frac{1}{v + p_j \lambda_{H,j}} \\ \text{s.t.} \quad \sum_{j=1}^L p_j \leq P_0, \\ p_i \geq 0, \quad 1 \leq i \leq L. \end{aligned} \quad (18.28)$$

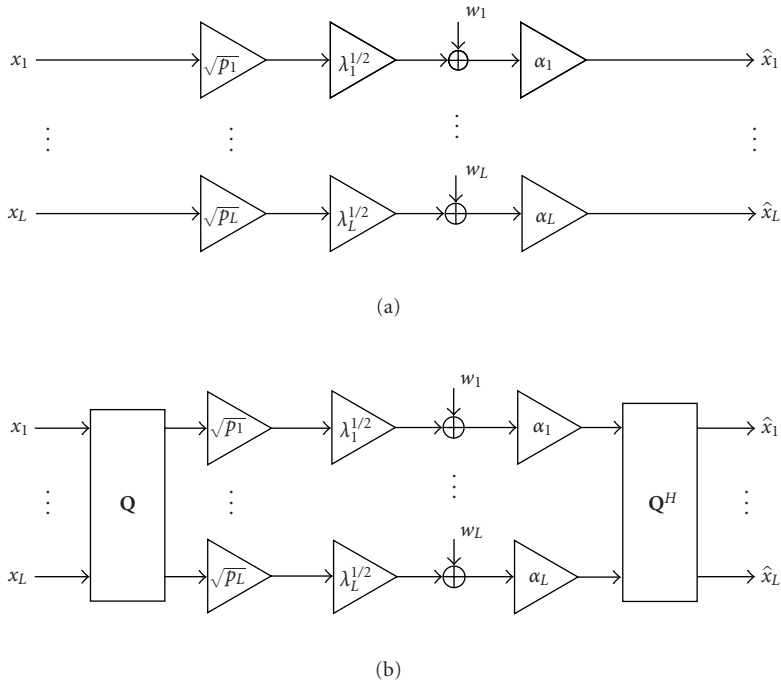

FIGURE 18.6. Scheme of diagonal and nondiagonal (due to the rotation) transmissions: (a) diagonal transmission and (b) nondiagonal (diagonal + rotation) transmission.

Surprisingly, this simplified problem for Schur-convex functions does not depend on the cost function f_0 . The reason is that all the MSEs are equal and f_0 is increasing in each argument; consequently, minimizing the cost function is equivalent to minimizing the equal arguments given by (18.27). In addition, problem (18.28) is solved by the following water-filling solution:

$$p_i = (\mu \lambda_{H,i}^{-1/2} - \nu \lambda_{H,i}^{-1})^+, \quad 1 \leq i \leq L, \quad (18.29)$$

where μ is the water level chosen such that $\sum_i p_i = P_0$ (see [43] for practical implementation of water-filling expressions). Note that for the ZF receiver ($\nu = 0$), the water-filling solution (18.29) simplifies to $p_i = P_0 \lambda_{H,i}^{-1/2} / \sum_j \lambda_{H,j}^{-1/2}$.

It is interesting to remark that problem (18.28) is equivalent to the minimization of the trace of the MSE matrix. Hence, among the infinite solutions that minimize $\text{Tr}(\mathbf{E})$, only that which yields equal diagonal elements in \mathbf{E} is the optimal solution for a Schur-convex objective function (which is obtained in fact with the water-filling solution in (18.29) and the rotation \mathbf{Q} as described in Theorem 18.1).

18.7. Diagonal versus nondiagonal transmission

To better understand the underlying structure of the communication when using an MMSE/ZF receiver and a transmitter of the form $\mathbf{B} = \mathbf{U}_{H,1} \mathbf{\Sigma}_B \mathbf{Q}$, write the global transmit-receive process $\hat{\mathbf{x}} = \mathbf{A}^H (\mathbf{H}\mathbf{B}\mathbf{x} + \mathbf{n})$ as

$$\hat{\mathbf{x}} = \mathbf{Q}^H (\nu \mathbf{I} + \mathbf{\Sigma}_B^H \mathbf{D}_{H,1} \mathbf{\Sigma}_B)^{-1} \mathbf{\Sigma}_B^H \mathbf{D}_{H,1}^{1/2} (\mathbf{D}_{H,1}^{1/2} \mathbf{\Sigma}_B \mathbf{Q}\mathbf{x} + \mathbf{w}), \quad (18.30)$$

where \mathbf{w} is an equivalent white noise and $\mathbf{D}_{H,1} = \mathbf{U}_{H,1}^H \mathbf{R}_H \mathbf{U}_{H,1}$ is the diagonalized squared whitened channel matrix. For the ZF receiver ($\nu = 0$), the previous expression simplifies to

$$\hat{\mathbf{x}} = \mathbf{x} + \mathbf{Q}^H (\mathbf{\Sigma}_B^H \mathbf{D}_{H,1} \mathbf{\Sigma}_B)^{-1/2} \mathbf{w} \quad (18.31)$$

which clearly satisfies the condition $\mathbf{A}^H \mathbf{H}\mathbf{B} = \mathbf{I}$ (by definition) but has, in general, a correlated noise among the substreams. In other words, when using the ZF receiver, the global transmission is not really diagonal or parallel since the noise is colored.

Interestingly, having a fully diagonal or parallel transmission does not depend on whether the ZF or the MMSE receivers are used, but on the choice of the rotation \mathbf{Q} (see Figure 18.6). Indeed, by setting $\mathbf{Q} = \mathbf{I}$, the global transmit-receive process is fully diagonalized:

$$\hat{\mathbf{x}} = (\nu \mathbf{I} + \mathbf{\Sigma}_B^H \mathbf{D}_{H,1} \mathbf{\Sigma}_B)^{-1} \mathbf{\Sigma}_B^H \mathbf{D}_{H,1}^{1/2} (\mathbf{D}_{H,1}^{1/2} \mathbf{\Sigma}_B \mathbf{x} + \mathbf{w}) \quad (18.32)$$

which can be rewritten as

$$\hat{x}_i = \alpha_i \left(\sqrt{p_i \lambda_{H,i}} x_i + w_i \right), \quad 1 \leq i \leq L, \quad (18.33)$$

where $\alpha_i = \sqrt{p_i \lambda_{H,i}} / (\nu + p_i \lambda_{H,i})$ (see Figure 18.6 with $\lambda_i \triangleq \lambda_{H,i}$). Note that when $\mathbf{Q} = \mathbf{I}$, the MMSE receiver also results in a diagonal transmission (which is never the case in the traditional approach where only the receiver is optimized).

18.8. Examples

The following list of Schur-concave and Schur-convex functions, along with the corresponding closed-form solutions, illustrates how powerful is the unifying framework developed in Theorem 18.1 (see [20, 40] for a detailed treatment of each case).

The following are examples of Schur-concave functions (when expressed as functions of the MSEs) for which the diagonal transmission is optimal:

- (i) minimization of the sum of the MSEs or, equivalently, of $\text{Tr}(\mathbf{E})$ [6, 15] with solution $p_i = (\mu \lambda_{H,i}^{-1/2} - \nu \lambda_{H,i}^{-1})^+$;

- (ii) minimization of the weighted sum of the MSEs or, equivalently, of $\text{Tr}(\mathbf{W}\mathbf{E})$ [16], where $\mathbf{W} = \text{diag}(\{w_i\})$ is a diagonal weighting matrix, with solution $p_i = (\mu w_i^{1/2} \lambda_{H,i}^{-1/2} - \nu \lambda_{H,i}^{-1})^+$;
- (iii) minimization of the (exponentially weighted) product of the MSEs with solution $p_i = (\mu w_i - \nu \lambda_{H,i}^{-1})^+$;
- (iv) minimization of $\det(\mathbf{E})$ [17] with solution $p_i = (\mu - \nu \lambda_{H,i}^{-1})^+$;
- (v) maximization of the mutual information, for example, [12], with solution $p_i = (\mu - \lambda_{H,i}^{-1})^+$;
- (vi) maximization of the (weighted) sum of the SINRs with solution given by allocating all the power on the channel eigenmode with highest weighted gain $w_i \lambda_{H,i}$;
- (vii) maximization of the (exponentially weighted) product of the SINRs with solution $p_i = P_0 w_i / \sum_j w_j$ (for the unweighted case, it results in a uniform power allocation).

The following are examples of Schur-convex functions for which the optimal transmission is nondiagonal with solution given by $p_i = (\mu \lambda_{H,i}^{-1/2} - \nu \lambda_{H,i}^{-1})^+$ plus the rotation \mathbf{Q} :

- (i) minimization of the maximum of the MSEs;
- (ii) maximization of the minimum of the SINRs;
- (iii) maximization of the harmonic mean of the SINRs;⁷
- (iv) minimization of the average BER (with equal constellations);
- (v) minimization of the maximum of the BERs.

In the following, two relevant examples (with an excellent performance in practice) are considered to illustrate how easily linear MIMO transceivers can be designed with the aid of Theorem 18.1.

18.8.1. Optimization of the worst substream

The optimization of the worst substream can be formulated, for example, as the minimization of the maximum MSE:

$$\min_{\mathbf{A}, \mathbf{B}} \max_i \{ \text{MSE}_i \} \quad (18.34)$$

which coincides with the minimization of the maximum BER if equal constellations are used. The optimal receive matrix is given by (18.14) and the problem reduces then to

$$\begin{aligned} \min_{\mathbf{B}} \max_i \left\{ [(\nu \mathbf{I} + \mathbf{B}^H \mathbf{R}_H \mathbf{B})^{-1}]_{ii} \right\} \\ \text{s.t. } \text{Tr}(\mathbf{B}\mathbf{B}^H) \leq P_0. \end{aligned} \quad (18.35)$$

⁷For the ZF receiver, the maximization of the harmonic mean of the SINRs is equivalent to the minimization of the unweighted sum of the MSEs, which can be classified as both Schur-concave and Schur-convex (since it is invariant to rotations).

Theorem 18.1 can now be invoked noting that $f_0(\mathbf{x}) = \max_i \{x_i\}$ is a Schur-convex function [20, 40] (if \mathbf{y} majorizes \mathbf{x} , it must be that $x_{\max} \leq y_{\max}$ from the definition of majorization [21, 1.A.1] and, therefore, $f_0(\mathbf{x}) \leq f_0(\mathbf{y})$ which is precisely the definition of Schur-convexity [21, 3.A.1]). Hence, the final problem to be solved is (18.28) with solution given by (18.29) (recall that the rotation matrix \mathbf{Q} is needed in this case as indicated in Theorem 18.1).

In light of Theorem 18.1 and the Schur-convexity of the cost function, it is now clear that the optimal transmission is nondiagonal (cf. Sections 18.6.2 and 18.7). However, one can still impose such a structure and solve the original problem in a suboptimal way. The transmit matrix would then be $\mathbf{B} = \mathbf{U}_{H,1} \Sigma_B$ and the problem to be solved in convex form:

$$\begin{aligned}
 & \min_{\mathbf{P}} t \\
 \text{s.t.} \quad & t \geq \frac{1}{v + p_i \lambda_{H,i}} \quad 1 \leq i \leq L \\
 & \sum_{j=1}^L p_j \leq P_0 \\
 & p_i \geq 0
 \end{aligned} \tag{18.36}$$

with solution given by $p_i = P_0 \lambda_{H,i}^{-1} / \sum_j \lambda_{H,j}^{-1}$.

18.8.2. Minimization of the average BER

The average (uncoded) BER is a good measure of the uncoded part of a system. Hence, its minimization may be regarded as an excellent (if not the best) criterion:

$$\min_{\mathbf{A}, \mathbf{B}} \frac{1}{L} \sum_{i=1}^L g_i(\text{MSE}_i), \tag{18.37}$$

where the functions g_i were defined in (18.19) and characterized as convex functions (see Figure 18.4). The optimal receive matrix is given by (18.14) and the problem reduces then to

$$\begin{aligned}
 & \min_{\mathbf{B}} \frac{1}{L} \sum_{i=1}^L g_i \left(\left[(v\mathbf{I} + \mathbf{B}^H \mathbf{R}_H \mathbf{B})^{-1} \right]_{ii} \right) \\
 \text{s.t.} \quad & \text{Tr}(\mathbf{B}\mathbf{B}^H) \leq P_0.
 \end{aligned} \tag{18.38}$$

Theorem 18.1 can now be invoked and the problem simplifies to the following

convex problem (provided that the constellations are chosen with increasing cardinality):

$$\begin{aligned}
 \min_{\mathbf{p}, \boldsymbol{\rho}} \quad & \frac{1}{L} \sum_{i=1}^L g_i(\rho_i) \\
 \text{s.t.} \quad & \sum_{j=i}^L \frac{1}{v + p_j \lambda_{H,j}} \leq \sum_{j=i}^L \rho_j, \quad 1 \leq i \leq L, \\
 & \sum_{j=1}^L p_j \leq P_0, \\
 & p_i \geq 0.
 \end{aligned} \tag{18.39}$$

This particular problem was extensively treated in [24] via a primal decomposition approach which allowed the resolution of the problem with extremely simple algorithms (rather than using general purpose iterative algorithms such as interior-point methods).

In the particular case in which the constellations used in the L substreams are equal, the average BER cost function turns out to be Schur-convex since it is the sum of identical convex functions [21, 3.H.2]. Hence, the final problem to be solved is again (18.28) with solution given by (18.29) (recall that the rotation matrix \mathbf{Q} is needed in this case as indicated in Theorem 18.1). As before, the minimization of the average BER can be suboptimally solved by imposing a diagonal structure.

18.9. Extension to parallel MIMO channels

As mentioned in Section 18.3, some particular scenarios, such as multicarrier systems, may be more conveniently modeled as a communication through a set of parallel MIMO channels

$$\mathbf{y}_k = \mathbf{H}_k \mathbf{s}_k + \mathbf{n}_k, \quad 1 \leq k \leq N, \tag{18.40}$$

where N is the number of parallel channels and k is the channel index.

It is important to remark that a multicarrier system can be modeled, not only as a set of parallel MIMO channels as in (18.40), but also as a single MIMO channel as in (18.1) with $\mathbf{H} = \text{diag}(\{\mathbf{H}_k\})$. The difference lies on whether the transceiver operates independently at each MIMO channel as implied by (18.40) (block-diagonal matrices $\mathbf{B} = \text{diag}(\{\mathbf{B}_k\})$ and $\mathbf{A} = \text{diag}(\{\mathbf{A}_k\})$) or a global transceiver processes jointly all MIMO channels as a whole as implied by (18.1) (full matrices \mathbf{B} and \mathbf{A}).

In the case of a set of N parallel MIMO channels with a single power constraint per channel, all the results obtained so far for a single MIMO channel clearly hold, since the optimization of a global cost function decouples into a set of N parallel optimization subproblems (under the mild assumption that the global

cost function f_0 depends on each MIMO channel through a subfunction f_k , that is, when it is of the form $f_0(\{f_k(\mathbf{x}_k)\})$.

When the power constraint is global for the whole set of parallel MIMO channels, as is usually the case in multicarrier systems, the problem formulation in (18.10) becomes

$$\begin{aligned} \min_{\{\mathbf{A}_k, \mathbf{B}_k, P_k\}} \quad & f_0(\{\text{MSE}_{k,i}\}) \\ \text{s.t.} \quad & \text{Tr}(\mathbf{B}_k \mathbf{B}_k^H) \leq P_k, \quad 1 \leq k \leq N, \\ & \sum_{k=1}^N P_k \leq P_0. \end{aligned} \tag{18.41}$$

For this problem, the results previously obtained for a single MIMO channel still hold, but some comments are in order.

(i) The optimal receiver and MSE matrix for each of the MIMO channels have the same form as (18.14) and (18.16), respectively.

(ii) Theorem 18.1 still holds for each of the MIMO channels, with the additional complexity that the power P_k used in each of them is also an optimization variable, which has to comply with the global power constraint $\sum_{k=1}^N P_k \leq P_0$. In particular, the resulting simplified problem is similar to (18.21) (which is convex provided that the cost function f_0 is) and the optimal transmitters have the same form as (18.22). When f_0 is Schur-concave/convex on a MIMO channel basis (i.e., when fixing the variables of all MIMO channels except the k th one, for all k), the simplifications (18.23) and (18.24) of the optimal transmitters are still valid.

(iii) The simplification of the problem for Schur-concave cost functions as described in Section 18.6.1 is still valid. For Schur-convex functions, however, the amazing simplification obtained in Section 18.6.2 is not valid anymore. That is, for multiple MIMO channels with a Schur-convex cost function f_0 , the solution is not independent of the particular choice of f_0 as happened in the single MIMO case (see problem (18.28) and the solution (18.29)); to be more specific, the difference of the solutions is on how the total power is allocated among the MIMO channels.

(iv) The optimal solutions obtained for multiple MIMO channels [20, 40] are, in general, more complicated than the simple water-filling expressions for a single MIMO channel given in Section 18.8. In many cases, the solutions still present a water-filling structure, but with several water levels coupled together [20, 40]. In any case, the numerical evaluation of such water-filling solutions can be implemented very efficiently in practice [43].

18.10. Numerical results

The aim of this section is not just to compare the different methods for designing MIMO transceivers, but to show that the design according to most criteria can now be actually solved using the unified framework.

In order to describe the simulation setup easily and since the observations and conclusions remain the same, a very simple model has been used to randomly

generate different realizations of the MIMO channel (for simulations with more realistic wireless multiantenna channel models including spatial and frequency correlation, the reader is referred to [20, 40]). In particular, the channel matrix \mathbf{H} has been drawn from a Gaussian distribution with i.i.d. elements of zero mean and unit variance, and the noise has been modeled as white $\mathbf{R}_n = \sigma_n^2 \mathbf{I}$, where σ_n^2 is the noise power. The SNR is defined as $\text{SNR} = P_T / \sigma_n^2$, which is essentially a measure of the transmitted power normalized with respect to the noise. The performance of the systems is measured in terms of BER averaged over the substreams; to be more precise, the outage BER⁸ (over different realizations of \mathbf{H}) is considered since it is a more realistic measure than the average BER (which only makes sense when the system does not have delay constraints and the duration of the transmission is sufficiently long such that the fading statistics of the channel can be averaged out).

For illustration purposes, four different methods have been simulated: the classical minimization of the sum of the MSEs (SUM-MSE), the minimization of the product of the MSEs (PROD-MSE), the optimization of the worst substream (see Section 18.8.1) or minimization of the maximum of the MSEs (MAX-MSE), and the minimization of the average BER (see Section 18.8.2) or, equivalently, of the sum of the BERs (SUM-BER). Note that the methods SUM-MSE and PROD-MSE correspond to Schur-concave cost functions, whereas the methods MAX-MSE and SUM-BER correspond to Schur-convex ones.

In Figure 18.7, the BER (for a QPSK constellation) is plotted as a function of the SNR for a 4×4 MIMO channel with $L = 3$ for the cases of ZF and MMSE receivers. The first observation is that the performance of the ZF receiver is basically the same as that of the MMSE receiver thanks to the joint optimization of the transmitter and receiver (as opposed to the typically worse performance of the ZF receiver in the classical equalization setup where only the receiver is optimized). Another observation is that the performance of the methods MAX-MSE and SUM-BER is, as expected, exactly the same because they both correspond to Schur-convex cost functions (cf. Section 18.6.2).

In Figure 18.8, the same scenario is considered but with multiple parallel MIMO channels ($N = 16$) and only for the MMSE receiver. Two different approaches have been taken to deal with the multiple MIMO channels: a *joint processing* among all channels by modeling them as a whole as in (18.1) and a *parallel processing* of the channels by modeling them explicitly as parallel MIMO channels as in (18.40) (cf. Section 18.9). The joint processing clearly outperforms the parallel processing; the difference, however, may be as small as 0.5 dB or as large as 2 dB at a BER of 10^{-4} , for example, depending on the method. Hence, it is not clear whether the increase of complexity of the joint processing is worth (note, however, that the difference of performance increases with the loading factor of the system defined as $L / \min(n_T, n_R)$). With a parallel processing, the methods MAX-MSE and SUM-BER are not equivalent albeit being both Schur-convex, as opposed to a joint processing (cf. Section 18.9).

⁸The outage BER is the BER that is attained with some given probability (when it is not satisfied, an outage event is declared).

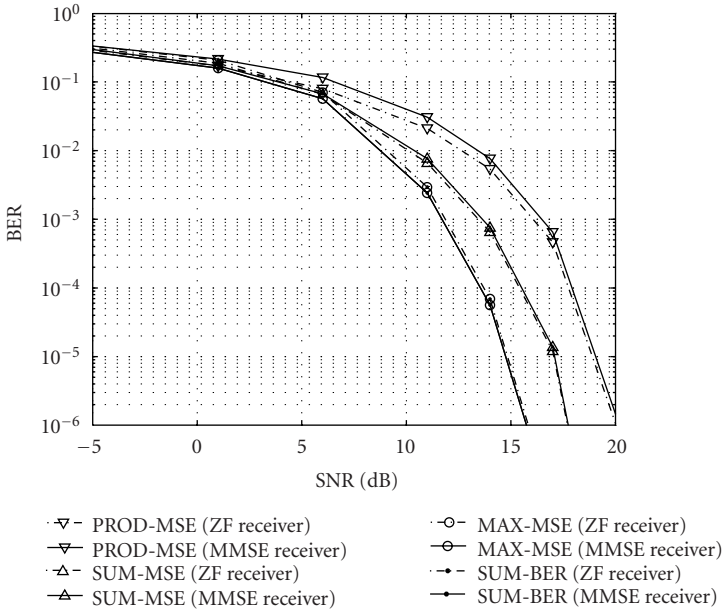

FIGURE 18.7. BER (at an outage probability of 5%) versus SNR when using QPSK in a 4×4 MIMO channel with $L = 3$ (with MMSE and ZF receivers) for the methods: PROD-MSE, SUM-MSE, MAX-MSE, and SUM-BER.

It is important to remark that Schur-convex methods are superior to Schur-concave ones (as observed from Figures 18.7 and 18.8). The reason is that Schur-concave methods transmit the symbols on a parallel fashion through the channel eigenmodes (diagonal structure), with the consequent lack of robustness to fading of some of the channel eigenmodes; whereas Schur-convex methods always transmit the symbols in a distributed way through the channels eigenmodes (nondiagonal structure), similar in essence to what CDMA systems do over the frequency domain. Among the Schur-convex methods, the SUM-BER is obviously the best (by definition) in terms of BER averaged over the substreams.

18.11. Summary

This chapter has dealt with the design of linear MIMO transceivers according to an arbitrary measure of the system quality. First, it has been observed that the results existing in the literature are isolated attempts under very specific design criteria such as the minimization of the trace of the MSE matrix. As a consequence, a unified framework has been proposed, which builds upon very recent results, to provide a systematic approach in the design of MIMO transceivers. Such a framework simplifies the original complicated problem to a simple convex problem which can then be tackled with the many existing tools in convex optimization theory (both numerical and analytical). In addition, for the family of Schur-concave/convex

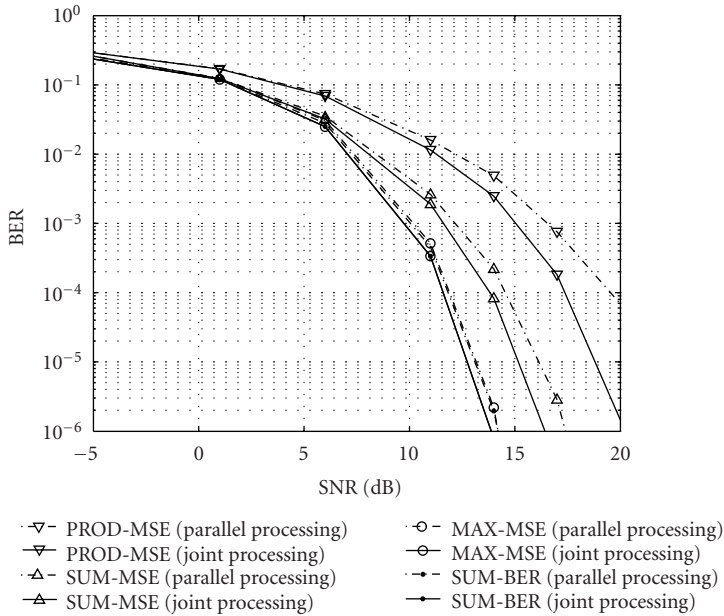

FIGURE 18.8. BER (at an outage probability of 5%) versus SNR (per MIMO channel) when using QPSK in 16 multiple 4×4 MIMO channels with $L = 3$ (with parallel and joint processing) for the methods: PROD-MSE, SUM-MSE, MAX-MSE, and SUM-BER.

functions, the problem simplifies further and practical solutions are obtained generally with a simple water-filling form.

Appendix

Sketch of the proof of Theorem 18.1

The proof hinges on majorization theory; the interested reader is referred to [21] for definitions and basic results on majorization theory (see also [40] for a brief overview) and to [20, 26, 40] for details overlooked in this sketch of the proof.

To start with, the problem (18.20) can be written as

$$\begin{aligned} \min_{\mathbf{B}, \boldsymbol{\rho}} f_0(\rho_1, \dots, \rho_L) \\ \text{s.t. } [(\nu \mathbf{I} + \mathbf{B}^H \mathbf{R}_H \mathbf{B})^{-1}]_{ii} \leq \rho_i, \quad 1 \leq i \leq L, \\ \text{Tr}(\mathbf{B} \mathbf{B}^H) \leq P_0 \end{aligned} \quad (\text{A.1})$$

which can always be done since f_0 is increasing in each argument. Also, since f_0 is minimized when $\rho_i \geq \rho_{i+1}$ and \mathbf{B} can always include any desired permutation such that the diagonal elements of $(\nu \mathbf{I} + \mathbf{B}^H \mathbf{R}_H \mathbf{B})^{-1}$ are in decreasing order, the constraint $\rho_i \geq \rho_{i+1}$ can be explicitly included without affecting the problem.

The first main simplification comes by rewriting the problem as [26, Theorem 2]

$$\begin{aligned}
 & \min_{\mathbf{B}, \boldsymbol{\rho}} f_0(\rho_1, \dots, \rho_L) \\
 & \text{s.t. } \tilde{\mathbf{B}}^H \mathbf{R}_H \tilde{\mathbf{B}} \text{ diagonal (increasing diag. elements),} \\
 & \mathbf{d}((\nu \mathbf{I} + \tilde{\mathbf{B}}^H \mathbf{R}_H \tilde{\mathbf{B}})^{-1}) \succ^w \boldsymbol{\rho}, \\
 & \rho_i \geq \rho_{i+1}, \\
 & \text{Tr}(\tilde{\mathbf{B}} \tilde{\mathbf{B}}^H) \leq P_0,
 \end{aligned} \tag{A.2}$$

where \succ^w denotes the weakly majorization relation⁹ [21] and $\mathbf{d}(\mathbf{X})$ denotes the diagonal elements of matrix \mathbf{X} (similarly, $\boldsymbol{\lambda}(\mathbf{X})$ is used for the eigenvalues). The second constraint guarantees the existence of a unitary matrix \mathbf{Q} such that $\mathbf{d}(\mathbf{Q}^H (\nu \mathbf{I} + \tilde{\mathbf{B}}^H \mathbf{R}_H \tilde{\mathbf{B}})^{-1} \mathbf{Q}) \leq \boldsymbol{\rho}$ [21, 9.B.2 and 5.A.9.a] or, in other words, such that $[(\nu \mathbf{I} + \tilde{\mathbf{B}}^H \mathbf{R}_H \tilde{\mathbf{B}})^{-1}]_{ii} \leq \rho_i$ with $\mathbf{B} = \tilde{\mathbf{B}} \mathbf{Q}$.

The second main simplification comes from the fact that $\tilde{\mathbf{B}}$ can be assumed without loss of optimality of the form $\tilde{\mathbf{B}} = \mathbf{U}_{H,1} \boldsymbol{\Sigma}_B$, as described in the theorem, since $\tilde{\mathbf{B}}^H \mathbf{R}_H \tilde{\mathbf{B}}$ is diagonal with diagonal elements in increasing order (cf. [20, Lemma 12], [26, Lemma 7], and [40, Lemma 5.11]).

Problem (18.21) follows then by plugging the expression of $\tilde{\mathbf{B}}$ into (A.2), denoting $p_i = |[\boldsymbol{\Sigma}_B]_{ii}|^2$ (which implies the need for the additional constraints $p_i \geq 0$), and by rewriting the weakly majorization constraint explicitly [21]. If f_0 is convex, the constraints $\rho_i \geq \rho_{i+1}$ are not necessary since an optimal solution cannot have $\rho_i < \rho_{i+1}$ (because the problem would have a lower objective value by using instead $\tilde{\rho}_i = \tilde{\rho}_{i+1} = (\rho_i + \rho_{i+1})/2$ [24]).

To obtain the additional simplification for Schur-concave/convex cost functions, rewrite the MSE constraints of (A.1) (since they are satisfied with equality at an optimal point) as

$$\boldsymbol{\rho} = \mathbf{d}(\mathbf{Q}^H (\nu \mathbf{I} + \tilde{\mathbf{B}}^H \mathbf{R}_H \tilde{\mathbf{B}})^{-1} \mathbf{Q}). \tag{A.3}$$

Now it suffices to use the definition of Schur-concavity/convexity to obtain the desired result. In particular, if f_0 is Schur-concave, it follows from the definition of Schur-concavity [21] (the diagonal elements and eigenvalues are assumed here in decreasing order) that

$$f_0(\mathbf{d}(\mathbf{X})) \geq f_0(\boldsymbol{\lambda}(\mathbf{X})) \tag{A.4}$$

which means that $f_0(\boldsymbol{\rho})$ is minimum when $\mathbf{Q} = \mathbf{I}$ in (A.3) (since $(\nu \mathbf{I} + \tilde{\mathbf{B}}^H \mathbf{R}_H \tilde{\mathbf{B}})^{-1}$ is already diagonal and with diagonal elements in decreasing order by definition).

⁹The weakly majorization relation $\mathbf{y} \succ^w \mathbf{x}$ is defined as $\sum_{j=i}^n y_j \leq \sum_{j=i}^n x_j$ for $1 \leq i \leq n$, where the elements of \mathbf{y} and \mathbf{x} are assumed in decreasing order [21].

If f_0 is Schur-convex, the opposite happens:

$$f_0(\mathbf{d}(\mathbf{X})) \geq f_0\left(\mathbf{1} \times \frac{\text{Tr}(\mathbf{X})}{L}\right), \quad (\text{A.5})$$

where $\mathbf{1}$ denotes the all-one vector. This means that $f_0(\boldsymbol{\rho})$ is minimum when \mathbf{Q} is such that $\boldsymbol{\rho}$ has equal elements in (A.3), that is, when $\mathbf{Q}^H(\nu\mathbf{I} + \tilde{\mathbf{B}}^H \mathbf{R}_H \tilde{\mathbf{B}})^{-1} \mathbf{Q}$ has equal diagonal elements.

Acknowledgment

This work was supported in part by the Fulbright Program and Spanish Ministry of Education and Science; the Catalan Government (DURSI) 2001SGR-00268; and the Spanish Government (CICYT) TIC2003-05482.

Abbreviations

BER	Bit error rate
BPSK	Binary phase-shift keying
CSI	Channel state information
DSL	Digital subscriber line
QAM	Quadrature amplitude modulation
QPSK	Quaternary phase-shift keying
MIMO	Multiple-input multiple-output
ML	Maximum likelihood
MMSE	Minimum MSE
MSE	Mean square error
SINR	Signal-to-interference-plus-noise ratio
SISO	Single-input single-output
ZF	Zero forcing

Bibliography

- [1] G. J. Foschini, "Layered space-time architecture for wireless communication in a fading environment when using multi-element antennas," *Bell Labs. Tech. J.*, vol. 1, no. 2, pp. 41–59, 1996.
- [2] G. G. Raleigh and J. M. Cioffi, "Spatio-temporal coding for wireless communication," *IEEE Trans. Commun.*, vol. 46, no. 3, pp. 357–366, 1998.
- [3] I. E. Telatar, "Capacity of multi-antenna Gaussian channels," *European Trans. Telecommunications*, vol. 10, no. 6, pp. 585–595, 1999.
- [4] G. J. Foschini and M. J. Gans, "On limits of wireless communications in a fading environment when using multiple antennas," *Wireless Personal Communications*, vol. 6, no. 3, pp. 311–335, 1998.
- [5] M. L. Honig, K. Steiglitz, and B. Gopinath, "Multichannel signal processing for data communications in the presence of crosstalk," *IEEE Trans. Commun.*, vol. 38, no. 4, pp. 551–558, 1990.
- [6] A. Scaglione, G. B. Giannakis, and S. Barbarossa, "Redundant filterbank precoders and equalizers. I. Unification and optimal designs," *IEEE Trans. Signal Processing*, vol. 47, no. 7, pp. 1988–2006, 1999.
- [7] S. M. Alamouti, "A simple transmit diversity technique for wireless communications," *IEEE J. Select. Areas Commun.*, vol. 16, no. 8, pp. 1451–1458, 1998.

- [8] V. Tarokh, N. Seshadri, and A. R. Calderbank, "Space-time codes for high data rate wireless communication: performance criterion and code construction," *IEEE Trans. Inform. Theory*, vol. 44, no. 2, pp. 744–765, 1998.
- [9] H. Bölcskei and A. J. Paulraj, "Multiple-input multiple-output (MIMO) wireless systems," in *The Communications Handbook*, J. Gibson, Ed., pp. 90.1–90.14, CRC Press, Boca Raton, Florida, USA, 2nd edition, 2002.
- [10] K. Miettinen, *Nonlinear Multiobjective Optimization*, Kluwer Academic Publishers, Boston, Mass, USA, 1999.
- [11] C. E. Shannon, "A mathematical theory of communication," *Bell System Tech. J.*, vol. 27, no. 4, pp. 379–423, 623–656, 1948.
- [12] T. M. Cover and J. A. Thomas, *Elements of Information Theory*, Wiley, New York, NY, USA, 1991.
- [13] K. H. Lee and D. P. Petersen, "Optimal linear coding for vector channels," *IEEE Trans. Commun.*, vol. 24, no. 12, pp. 1283–1290, 1976.
- [14] J. Salz, "Digital transmission over cross-coupled line channels," *AT&T Technical Journal*, vol. 64, no. 6, pp. 1147–1159, 1985.
- [15] J. Yang and S. Roy, "On joint transmitter and receiver optimization for multiple-input-multiple-output (MIMO) transmission systems," *IEEE Trans. Commun.*, vol. 42, no. 12, pp. 3221–3231, 1994.
- [16] H. Sampath, P. Stoica, and A. Paulraj, "Generalized linear precoder and decoder design for MIMO channels using the weighted MMSE criterion," *IEEE Trans. Commun.*, vol. 49, no. 12, pp. 2198–2206, 2001.
- [17] J. Yang and S. Roy, "Joint transmitter-receiver optimization for multi-input multi-output systems with decision feedback," *IEEE Trans. Inform. Theory*, vol. 40, no. 5, pp. 1334–1347, 1994.
- [18] A. Scaglione, P. Stoica, S. Barbarossa, G. B. Giannakis, and H. Sampath, "Optimal designs for space-time linear precoders and decoders," *IEEE Trans. Signal Processing*, vol. 50, no. 5, pp. 1051–1064, 2002.
- [19] A. Scaglione, S. Barbarossa, and G. B. Giannakis, "Filterbank transceivers optimizing information rate in block transmissions over dispersive channels," *IEEE Trans. Inform. Theory*, vol. 45, no. 3, pp. 1019–1032, 1999.
- [20] D. P. Palomar, J. M. Cioffi, and M. A. Lagunas, "Joint Tx-Rx beamforming design for multicarrier MIMO channels: a unified framework for convex optimization," *IEEE Trans. Signal Processing*, vol. 51, no. 9, pp. 2381–2401, 2003.
- [21] A. W. Marshall and I. Olkin, *Inequalities: Theory of Majorizations and Its Applications*, Academic Press, New York, NY, USA, 1979.
- [22] E. N. Onggosanusi, A. M. Sayeed, and B. D. V. Veen, "Efficient signaling schemes for wideband space-time wireless channels using channel state information," *IEEE Trans. Veh. Technol.*, vol. 52, no. 1, pp. 1–13, 2003.
- [23] Y. Ding, T. N. Davidson, Z.-Q. Luo, and K. M. Wong, "Minimum BER block precoders for zero-forcing equalization," *IEEE Trans. Signal Processing*, vol. 51, no. 9, pp. 2410–2423, 2003.
- [24] D. P. Palomar, M. Bengtsson, and B. Ottersten, "Minimum BER linear transceivers for MIMO channels via primal decomposition," to appear in *IEEE Trans. Signal Processing*, 2005.
- [25] M. Bengtsson and B. Ottersten, "Optimal and suboptimal transmit beamforming," in *Handbook of Antennas in Wireless Communications*, L. C. Godara, Ed., CRC Press, Boca Raton, Fla, USA, 2001.
- [26] D. P. Palomar, M. A. Lagunas, and J. M. Cioffi, "Optimum linear joint transmit-receive processing for MIMO channels with QoS constraints," *IEEE Trans. Signal Processing*, vol. 52, no. 5, pp. 1179–1197, 2004.
- [27] J. Milanovic, T. N. Davidson, Z.-Q. Luo, and K. M. Wong, "Design of robust redundant precoding filter banks with zero-forcing equalizers for unknown frequency-selective channels," in *Proc. 2000 IEEE International Conference on Acoustics, Speech, and Signal Processing (ICASSP '00)*, vol. 5, pp. 2761–2764, Istanbul, Turkey, June 2000.
- [28] F. Rey, M. Lamarca, and G. Vázquez, "Robust power allocation algorithms for MIMO OFDM systems with imperfect CSI," *IEEE Trans. Signal Processing*, vol. 53, no. 3, pp. 1070–1085, 2005.

- [29] G. Jöngren, M. Skoglund, and B. Ottersten, "Combining beamforming and orthogonal space-time block coding," *IEEE Trans. Inform. Theory*, vol. 48, no. 3, pp. 611–627, 2002.
- [30] J.-H. Chang, L. Tassiulas, and F. Rashid-Farrokhi, "Joint transmitter receiver diversity for efficient space division multiaccess," *IEEE Transactions on Wireless Communications*, vol. 1, no. 1, pp. 16–27, 2002.
- [31] Z.-Q. Luo, T. N. Davidson, G. B. Giannakis, and K. M. Wong, "Transceiver optimization for block-based multiple access through ISI channels," *IEEE Trans. Signal Processing*, vol. 52, no. 4, pp. 1037–1052, 2004.
- [32] R. H. Gohary, T. N. Davidson, and Z.-Q. Luo, "An efficient design method for vector broadcast systems with common information," in *Proc. IEEE Global Telecommunications Conference (GLOBECOM '03)*, vol. 4, pp. 2010–2014, San Francisco, Calif, USA, December 2003.
- [33] M. Bengtsson, "A pragmatic approach to multi-user spatial multiplexing," in *Proc. 2nd IEEE Sensor Array and Multichannel Signal Processing Workshop (SAM-2002)*, pp. 130–134, Rosslyn, Va, USA, August 2002.
- [34] E. Jorswieck and H. Boche, "Transmission strategies for the MIMO MAC with MMSE receiver: average MSE optimization and achievable individual MSE region," *IEEE Trans. Signal Processing*, vol. 51, no. 11, pp. 2872–2881, 2003.
- [35] S. Boyd and L. Vandenberghe, *Convex Optimization*, Cambridge University Press, Cambridge, Mass, USA, 2004.
- [36] D. P. Bertsekas, *Nonlinear Programming*, Athena Scientific, Belmont, Mass, USA, 2nd edition, 1999.
- [37] S. Benedetto and E. Biglieri, *Principles of Digital Transmission with Wireless Applications*, Kluwer Academic Publishers, New York, NY, USA, 1999.
- [38] S. Verdú, *Multuser Detection*, Cambridge University Press, New York, NY, USA, 1998.
- [39] K. Cho and D. Yoon, "On the general BER expression of one- and two-dimensional amplitude modulations," *IEEE Trans. Commun.*, vol. 50, no. 7, pp. 1074–1080, 2002.
- [40] D. P. Palomar, *A unified framework for communications through MIMO channels*, Ph.D. dissertation, Technical University of Catalonia (UPC), Barcelona, Spain, 2003.
- [41] S. M. Kay, *Fundamentals of Statistical Signal Processing: Estimation Theory*, vol. 1, Prentice Hall, Englewood Cliffs, NJ, USA, 1993.
- [42] P. Viswanath and V. Anantharam, "Optimal sequences and sum capacity of synchronous CDMA systems," *IEEE Trans. Inform. Theory*, vol. 45, no. 6, pp. 1984–1991, 1999.
- [43] D. P. Palomar and J. R. Fonollosa, "Practical algorithms for a family of waterfilling solutions," *IEEE Trans. Signal Processing*, vol. 53, no. 2, pp. 686–695, 2005.

Daniel Pérez Palomar: Department of Electrical Engineering, Princeton University, Princeton, NJ 08544, USA

Email: danielp@princeton.edu